

### Features

- 2.75x1.85x0.90mm Bottom Port
- Single Ended Analog Output
- SNR of 63dBA
- RF Shielded
- Compatible with Standard SMD Reflow Technology
- RoHS Compliance & Halogen Free

### Applications

- Smart Phones
- TWS Headsets
- Smart Speakers
- Wearable Electronics
- Portable Electronics
- Smart Home Electronics
- Laptop Computers

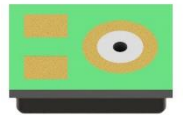

**Description** RMIC-94-3.6-2718-RG-NS8 is a small package, single-ended output bottom port analog MEMS microphone. The MEMS Microphones are integrated with specialized Pre-amplification ASIC to provide high sensitivity, high SNR output from a capacitive audio sensor. It's packaged for surface mounting and high temperature re-flow assembly.

### BLOCK DIAGRAM

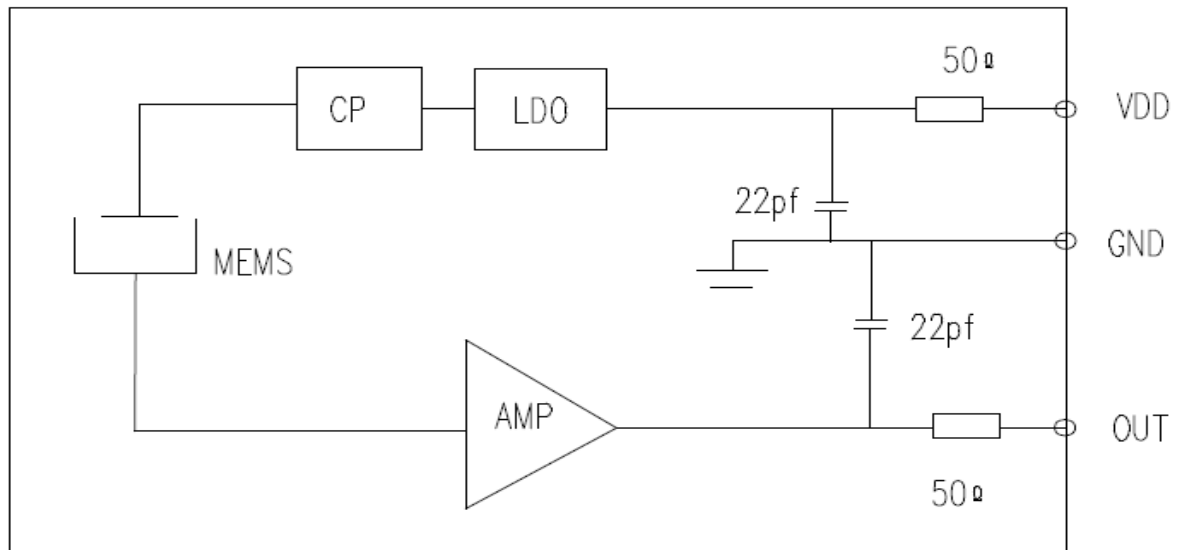

### ABSOLUTE MAXIMUM RATINGS

Parameters	Value			Unit
	min	typ	max	
Supply Voltage			3.6	V
Operation Temperature Range	-40		+100	°C
Storage Temperature Range	-40		+100	°C

Note : Stresses at the maximum ratings shown in Table may cause permanent damage to the device. These are stress ratings only at which the device may not function when an operation at these or any other condition beyond those specified under "Electro-Acoustic Specifications".

### ELECTRICAL SPECIFICATIONS

Test condition: Vdd=2.7V, no load, unless otherwise specified.

Parameters		Value			Unit
		min	typ	max	
Directivity		Omni-Directional			
Sensitivity (S)	94db SPL@ 1kHz	-39	-38	-37	dB
Current Consumption (I)	2.3V to 3.6V		120	200	uA
Operating Voltage	Vdd	2.3	2.7	3.6	V
Output Impedance	@1kHz			400	Ω
S/N Ratio (SNR)	BW=20-20KHz A-Weight, 1KHz		63		dBA
Sensitivity vs Voltage	VS=3.6 to 2.3V	<0.5			dB
Total Harmonic Distortion (THD)	@ 94dB SPL @1kHz		0.15	0.5	%
Acoustic Overload Point (AOP)	@10% THD @1kHz		130		dB
Power Supply Rejection (PSR, PSR+N)	@100mVpp Square wave, 217Hz, A-weighted		-100	-80	dB
			-96	-90	
Power Supply Rejection Ratio (PSRR)	@200mVpp Sinewave @1KHz	60	70		dB
DC Output	Vdc		1.10		V
Phase	100-10KHz	-5		5	Degree
Output Load	@ Cload			150	pF
	@ Rload	10		100	kΩ

Note: Frequency response, sensitivity, phase and current consumption are tested by 100% on product line.

### DIMENSIONS

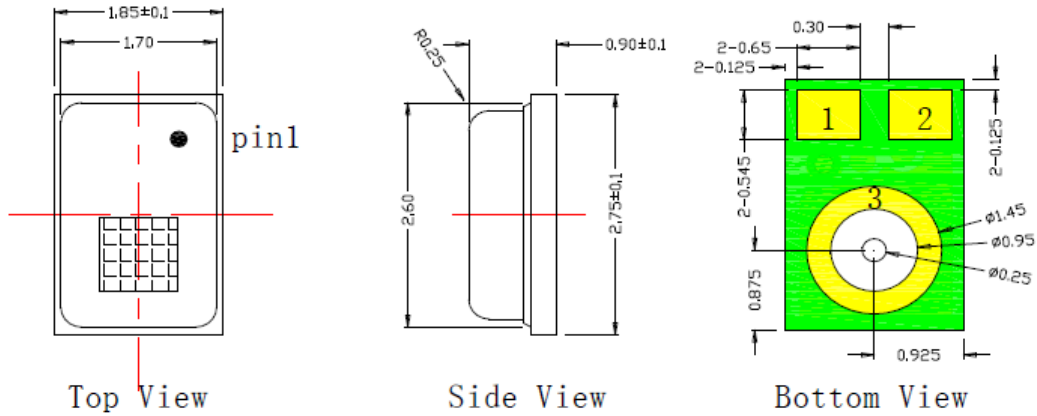

Unit: mm Unmarked Tolerance: ± 0.1 (mm)

Item	Dimension	Tolerance(+/-)
Length(L)	2.75	0.10
Width(W)	1.85	0.10
Height(H)	0.90	0.10
Acoustic Port(AP)	Ø0.25	0.05

Pin	Pin Name
1	V <sub>DD</sub>
2	Output
3	GND

### PICKUP TOOL PICK LOCATION & PCB SOLDER PAD LAYOUT

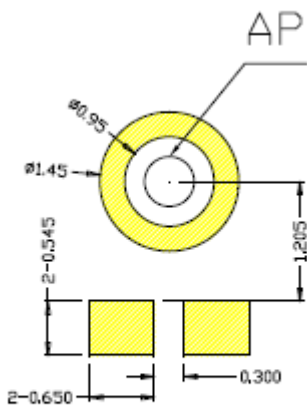

PCB land pattern

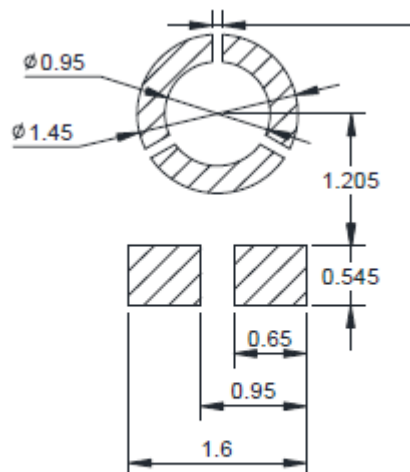

Solder Stencil Pattern

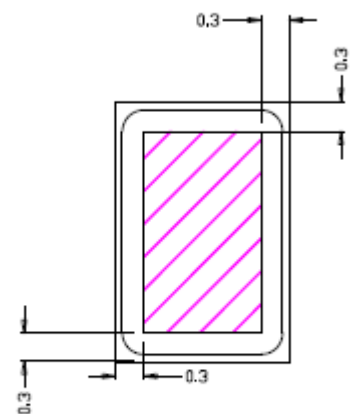

Pick up area

## FREQUENCY CHARACTERISTICS

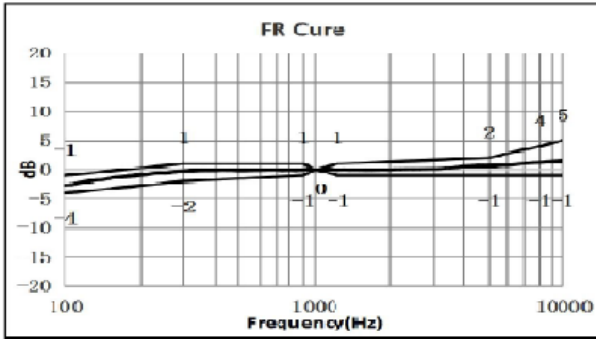

Frequency response curve normalized to 1kHz

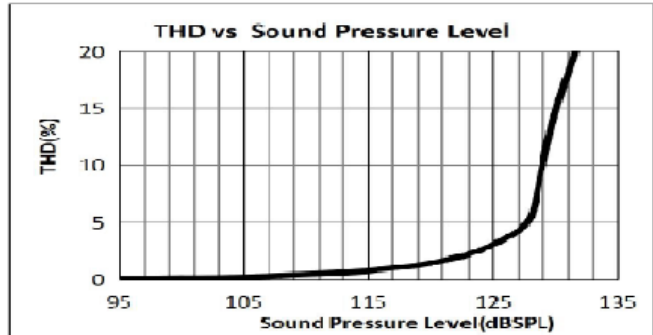

Typical THD vs Sound Pressure Level

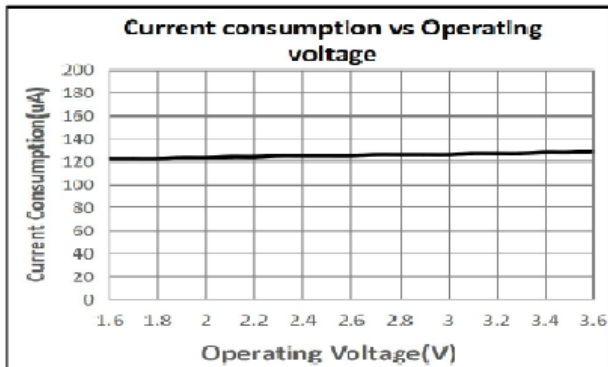

Current consumption vs Operating voltage

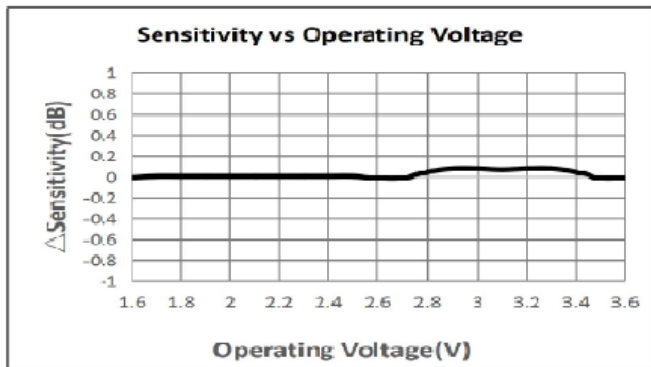

Sensitivity vs Operating Voltage

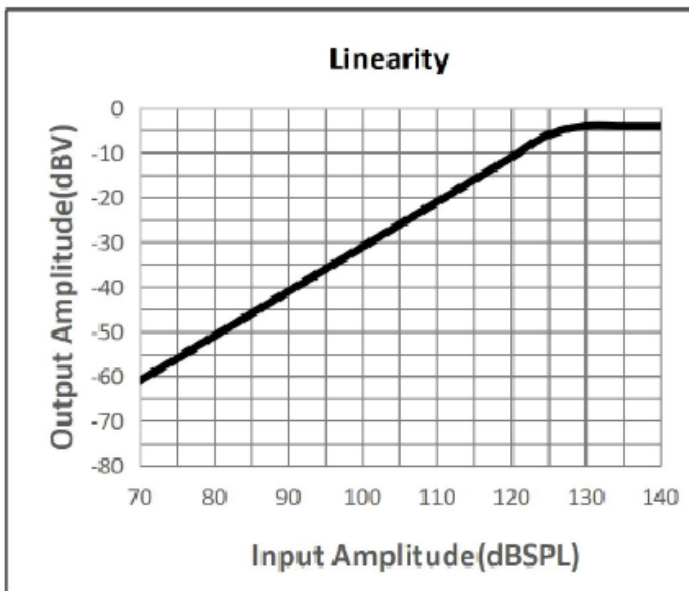

Linearity

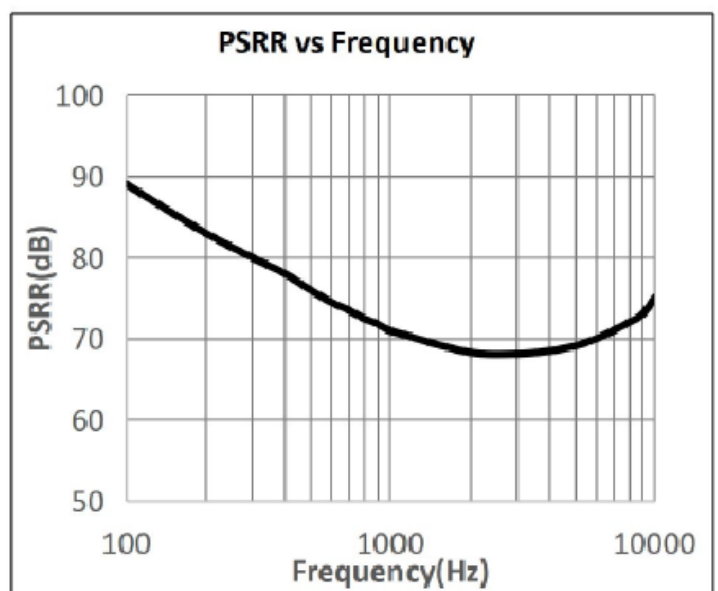

Typical PSRR cure

## MEASUREMENT SYSTEM SETUP

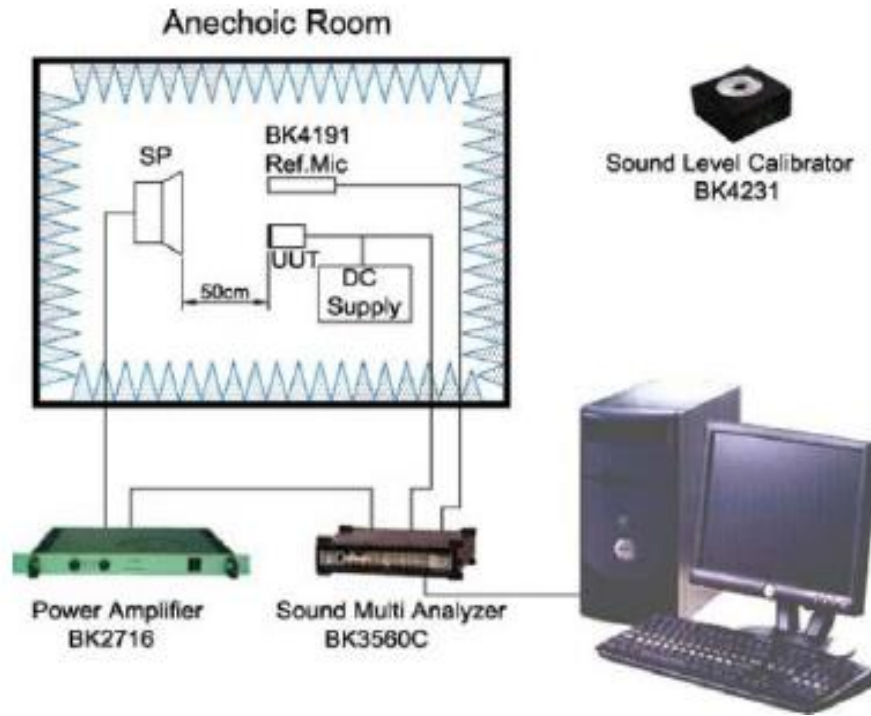

## TYPICAL APPLICATION CIRCUIT

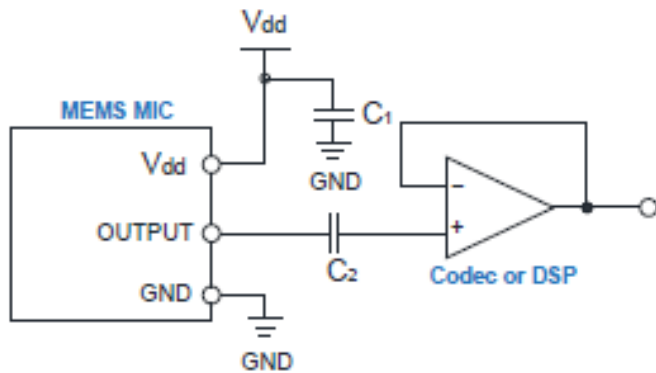

Single ended input interface circuit

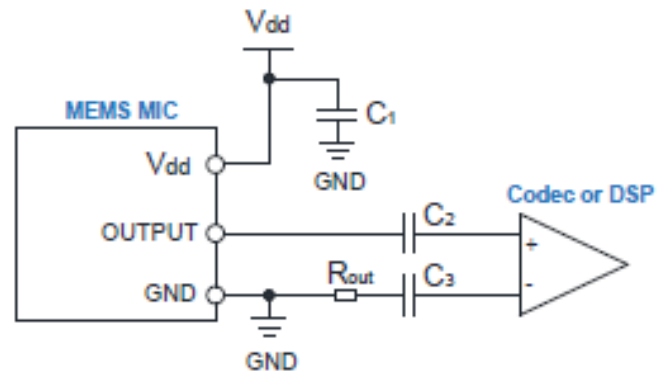

Differential input interface circuit

## REFLOW PROFILE

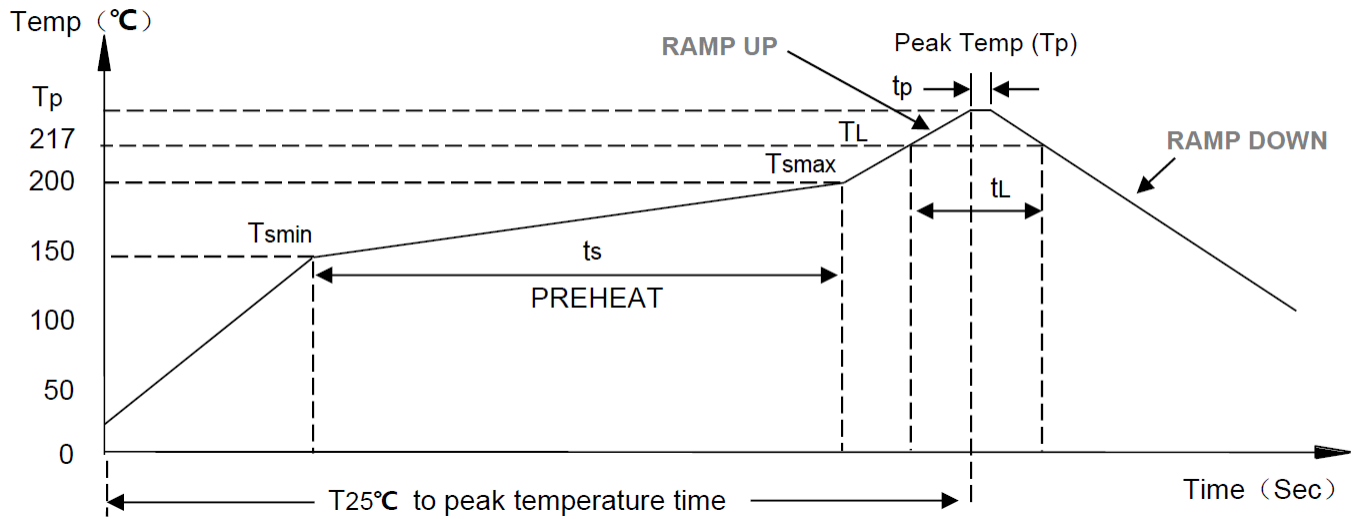

Parameter		Specification
Average temperature change rate (TSMAX to TP)		3°C /second max.
Preheat	Temperature min.(T <sub>SMIN</sub> )	150°C
	Temperature max.(T <sub>SMAX</sub> )	200°C
	Time T <sub>SMIN</sub> to T <sub>SMAX</sub>	60-180 Seconds
Time Maintained Above Liquidous		60-150 Seconds
Liquidous Temperature		217°C
Peak Temperature		260°C +0°C/-5°C
Time Within +5°C of Actual Peak Temperature		20 sec to 40 sec
Ramp-Down Rate		3°C/sec max
Time +25°C (t <sub>25°C</sub> ) to Peak Temperature		8 min max

### PACKAGING

13" Reel drawing:

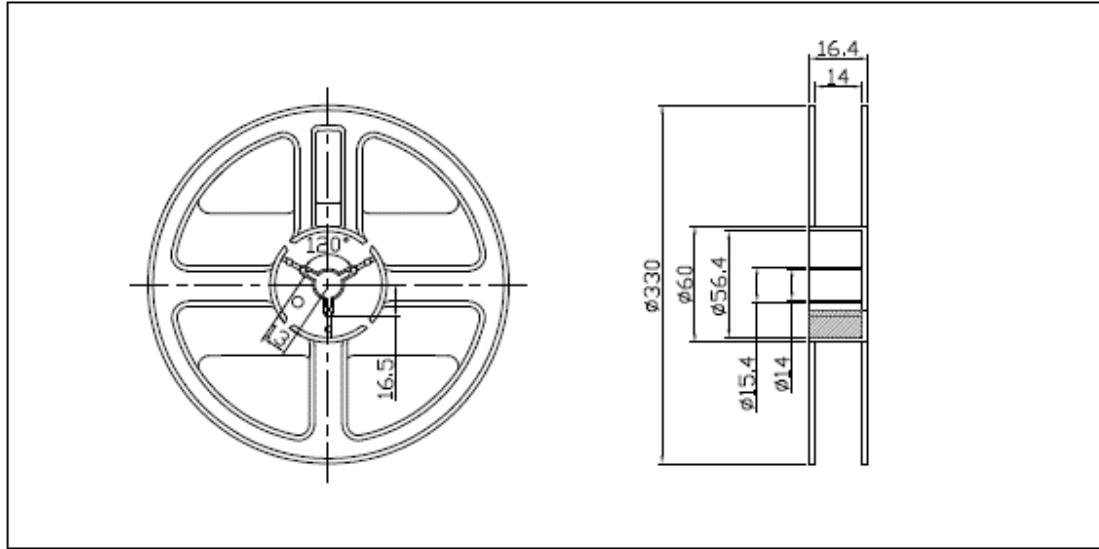

Tape drawing:

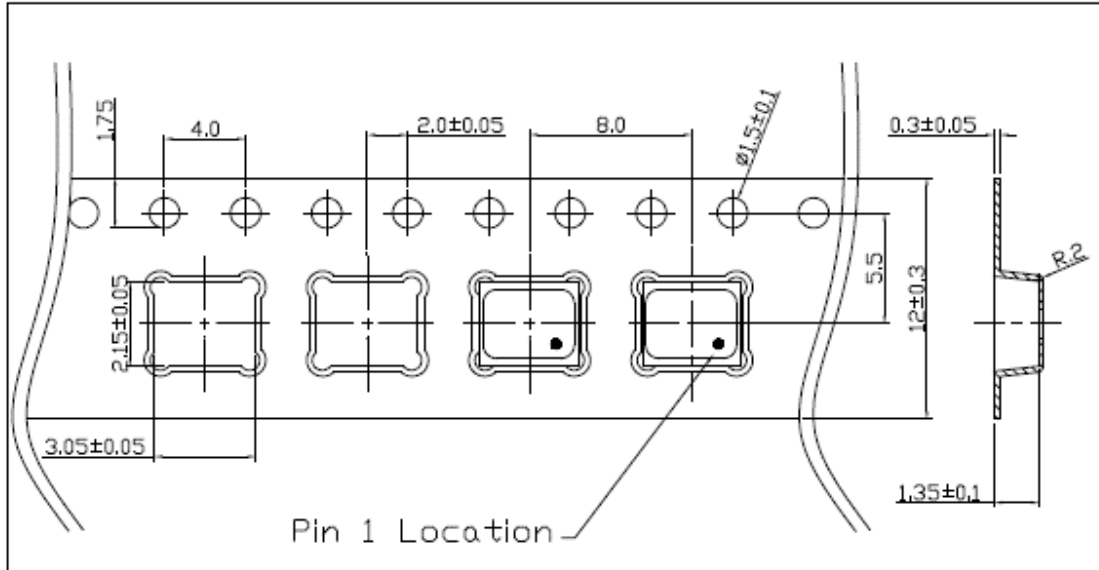

### APPROVAL

DRAWN BY	JS, May 28, 2024
APPROVED BY	AR, May 28, 2024
REVISION	A, Initial Release