

Features

- 2.75x1.85x0.90mm Bottom Port
- Single Ended Analog Output
- SNR of 63dBA
- RF Shielded
- Compatible with Standard SMD Reflow Technology
- RoHS Compliance & Halogen Free

Applications

- Smart Phones
- TWS Headsets
- Smart Speakers
- Wearable Electronics
- Portable Electronics
- Smart Home Electronics
- Laptop Computers

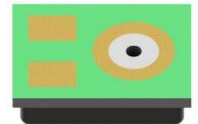

Description RMIC-94-3.6-2718-RG-NS6 is a small package, single-ended output bottom port analog MEMSmicrophone. The MEMS Microphones are integrated with specialized Pre-amplification ASIC to provide high sensitivity, high SNR output from a capacitive audiosensor. It's packaged for surface mounting and high temperature re-flow assembly.

BLOCK DIAGRAM

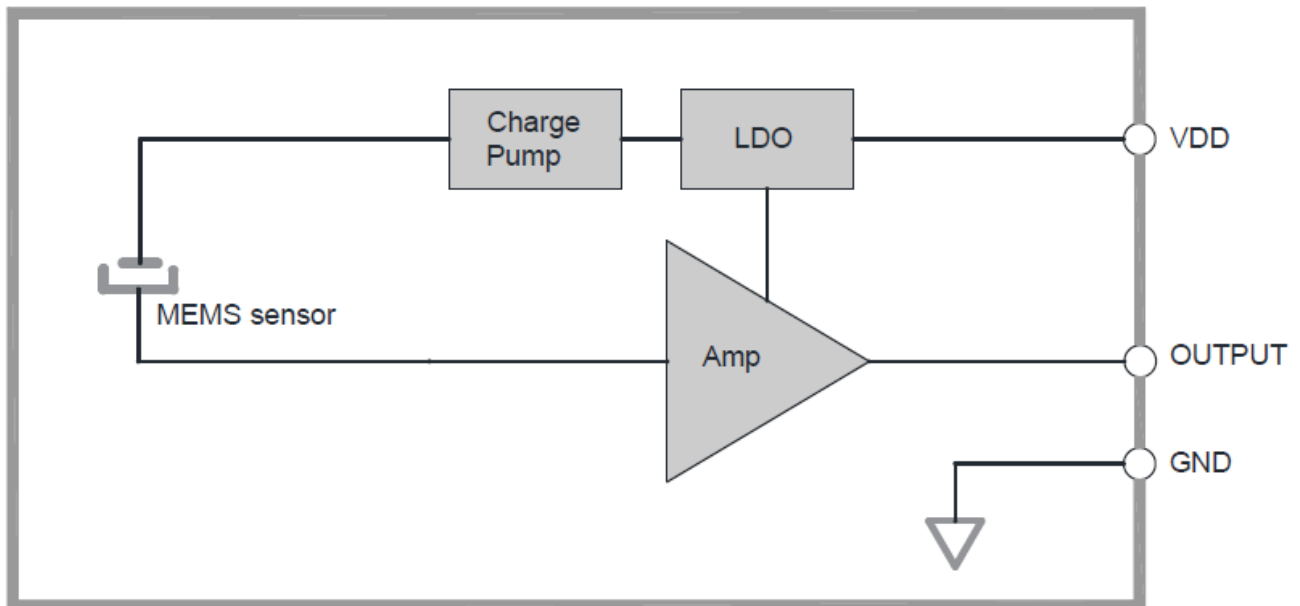

ABSOLUTE MAXIMUM RATINGS

Parameters	Value			Unit
	min	typ	max	
Supply Voltage			3.6	V
Operation Temperature Range	-40		+85	°C
Storage Temperature Range	-40		+125	°C

Note: Stresses at the maximum ratings shown in Table may cause permanent damage to the device. These are stress ratings only at which the device may not function when an operation at these or any other condition beyond those specified under "Electro-Acoustic Specifications".

ELECTRICAL SPECIFICATIONS

Test condition: Vdd=2.0V, no load, unless otherwise specified.

Parameters		Value			Unit
		min	typ	max	
Directivity		Omni-Directional			
Sensitivity (S)	94db SPL@ 1kHz	-39	-38	-37	dB
Current Consumption (I)	1.6V to 3.6V		120	160	uA
Operating Voltage	Vdd	1.6	2.0	3.6	V
Output Impedance	@1kHz			300	Ω
S/N Ratio (SNR)	@ 20-20kHz Bandwidth, A-Weighted	62	63		dBA
Sensitivity vs Voltage	VS=3.6 to 1.6V	<0.5			dB
Total Harmonic Distortion (THD)	@ 94dB SPL @1kHz		0.15	0.5	%
Acoustic Overload Point (AOP)	@10% THD @1kHz		128		dB
Power Supply Rejection (PSR, PSR+N)	@100mVpp Square wave, 217Hz, A-weighted		-100	-90	dB
			-96	-90	
Power Supply Rejection Ratio (PSRR)	@200mVpp Sinewave @1kHz	65	70		dB
DC Output	VDC		0.80		V
Phase	100-10KHz	-5		5	Degree
Output Load	@ Cload			150	pF
	@ Rload	10		100	kΩ

Note: Frequency response, sensitivity, phase and current consumption are tested by 100% on product line.

DIMENSIONS

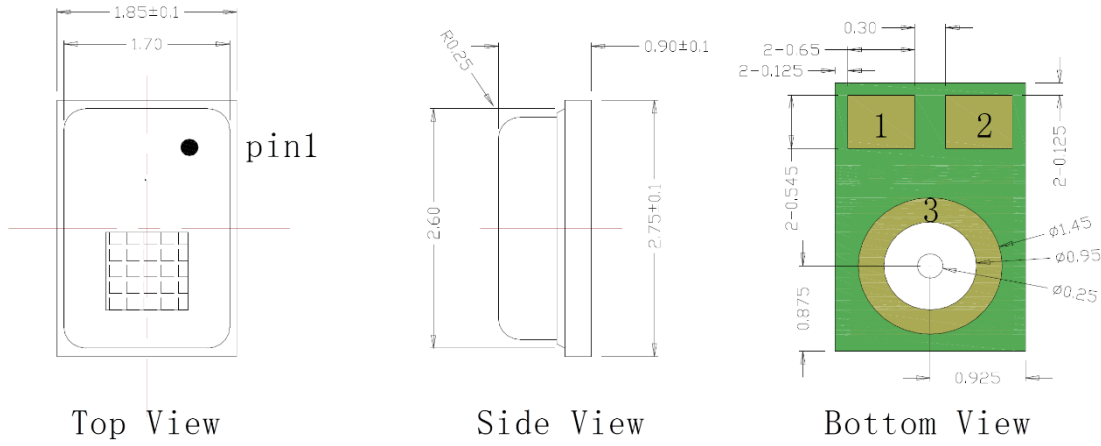

Unit: mm Unmarked Tolerance: ± 0.1 (mm)

Item	Dimension	Tolerance(+/-)
Length(L)	2.75	0.10
Width(W)	1.85	0.10
Height(H)	0.90	0.10
Acoustic Port(AP)	$\phi 0.25$	0.05

Pin	Pin Name
1	V_{DD}
2	Output
3	GND

FREQUENCY CHARACTERISTICS

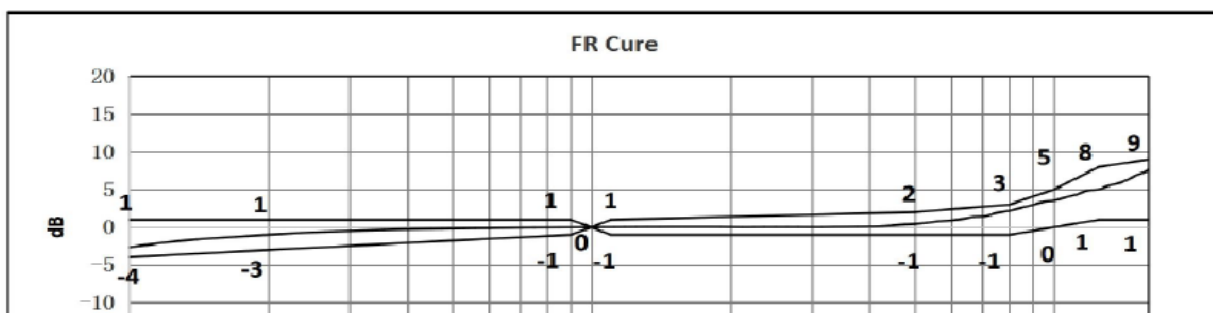

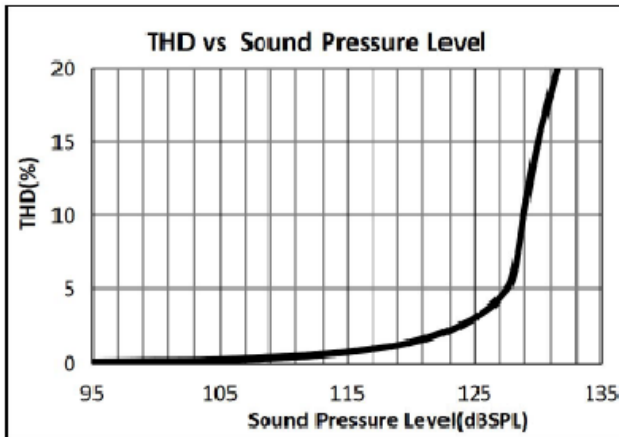

Typical THD vs Sound Pressure Level

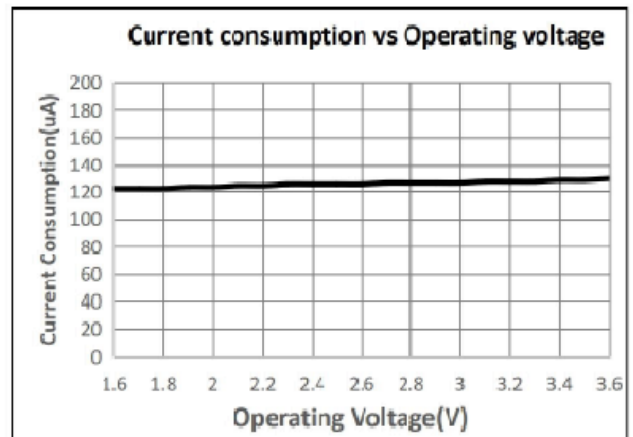

Current consumption vs Operating voltage

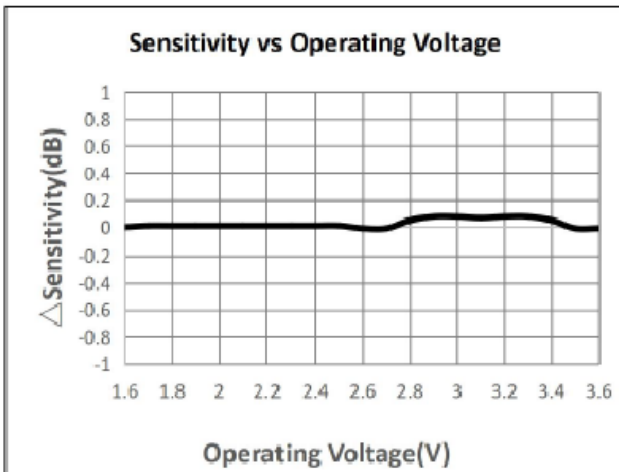

Sensitivity vs Operating Voltage

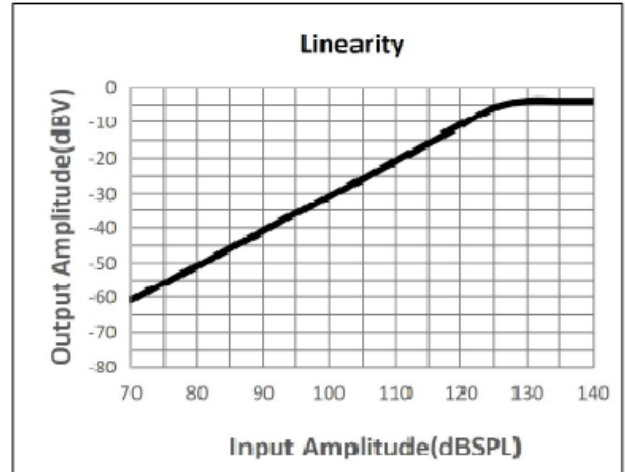

Linearity

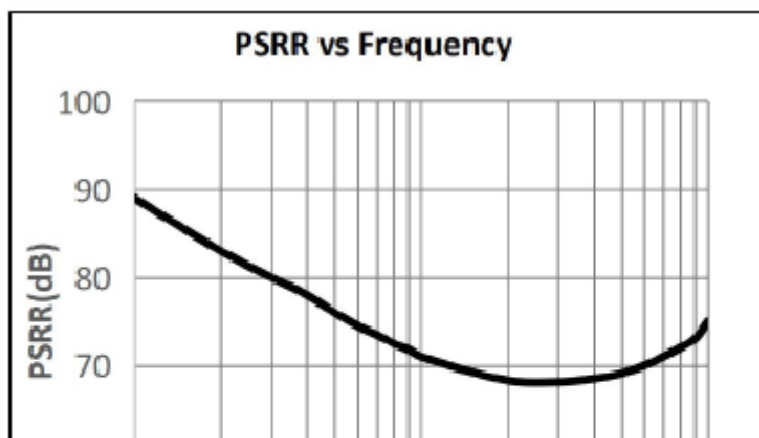

MEASUREMENT SYSTEM SETUP

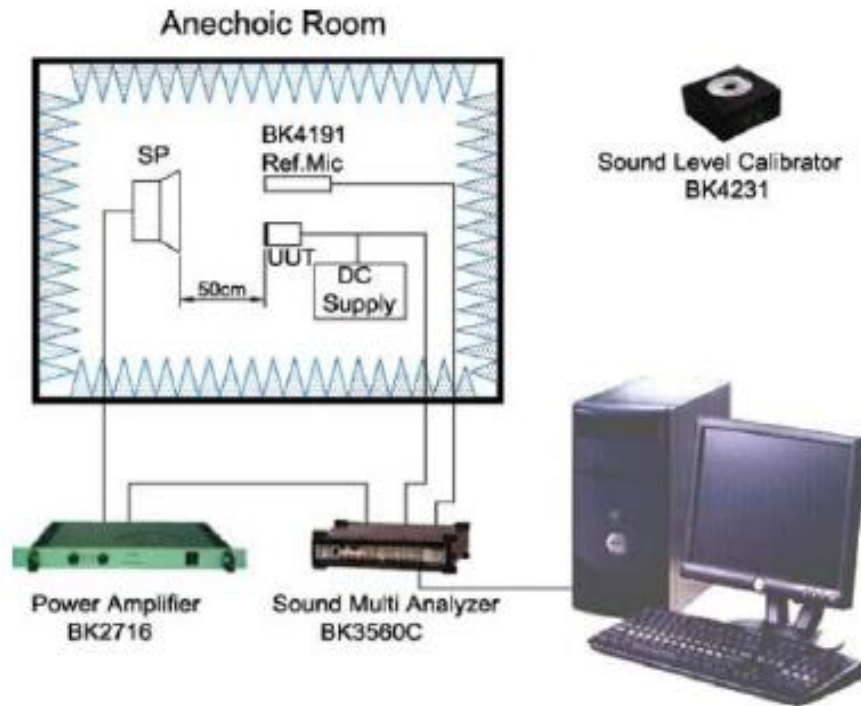

TYPICAL APPLICATION CIRCUIT

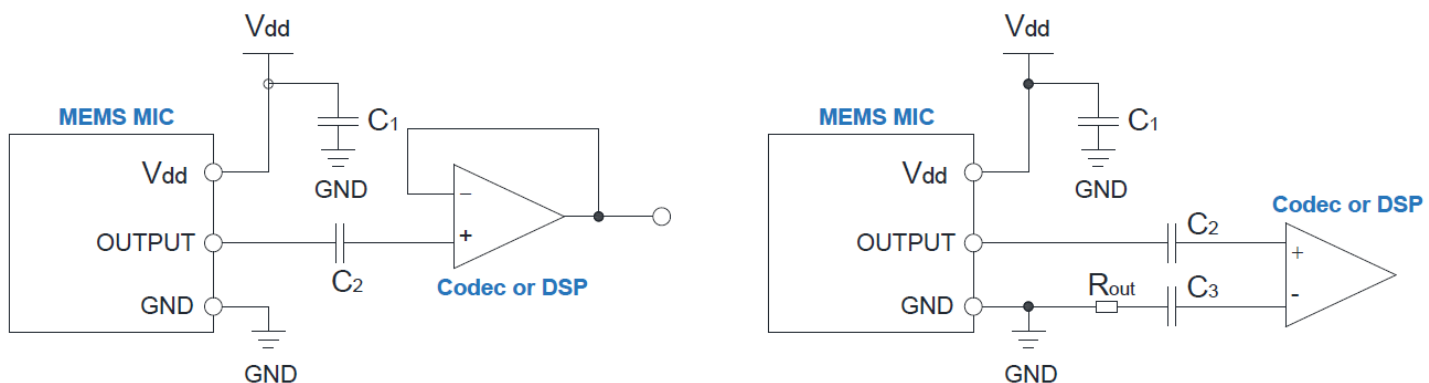

REFLOW PROFILE

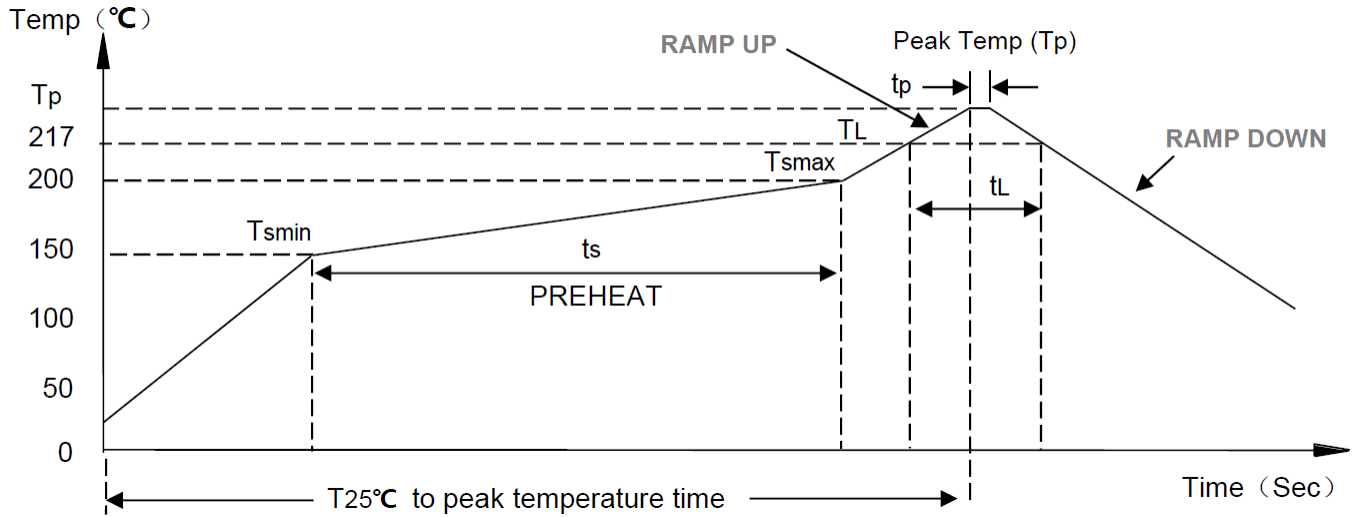

Parameter		Specification
Average temperature change rate (TSMAX to TP)		3°C /second max.
Preheat	Temperature min.(T_{SMIN})	150°C
	Temperature max.(T_{SMAX})	200°C
	Time T_{SMIN} to T_{SMAX}	60-180 Seconds
Time Maintained Above Liquidous		60-150 Seconds
Liquidous Temperature		217°C
Peak Temperature		260°C +0°C/-5°C
Time Within +5°C of Actual Peak Temperature		20 sec to 40 sec
Ramp-Down Rate		3°C/sec max
Time +25°C ($t_{25°C}$) to Peak Temperature		8 min max

PACKAGING

13" Reel drawing:

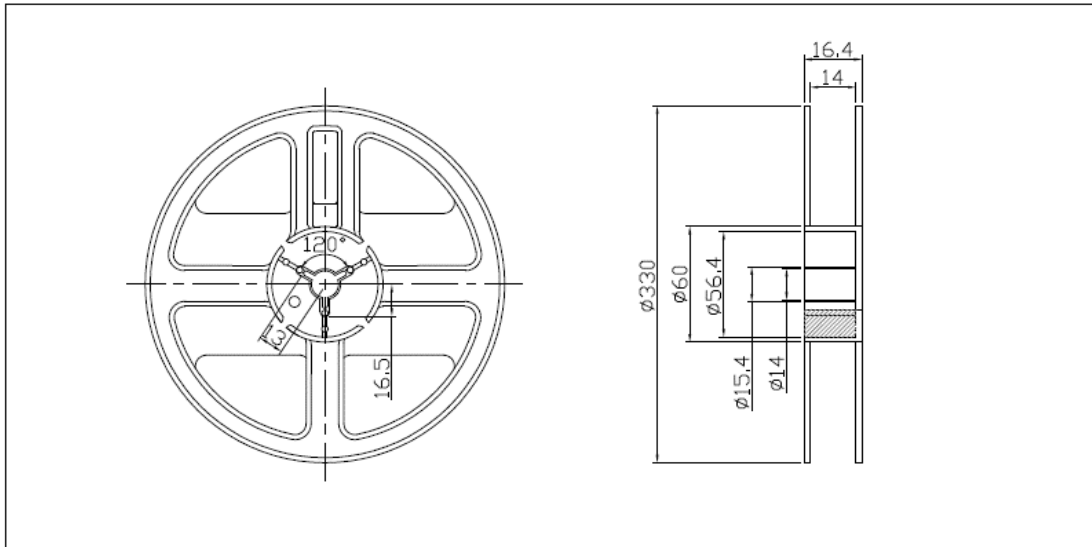

Tape drawing:

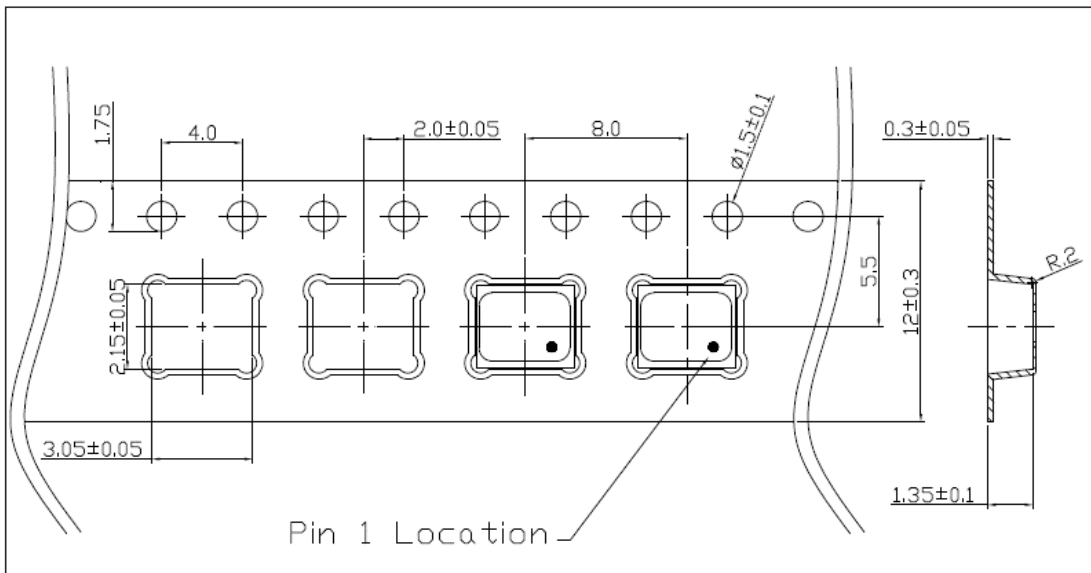

APPROVAL

DRAWN BY	JS, May 28, 2024
APPROVED BY	AR, May 28, 2024
REVISION	A, Initial Release

Raltron Electronics / RAMI Technology USA, LLC, including its affiliates, employees, agents and other persons acting on its behalf (collectively Raltron/RAMI Tech), disclaim any and all liability for any errors or inaccuracies contained in this data sheet. While Raltron/RAMI Tech has made every reasonable effort to ensure the accuracy of all product information, specifications and data contained herein, Raltron/RAMI Tech does not guarantee that the information is accurate, reliable or current. The product information is provided only for reference purposes only and is subject to change, correction or revision, at any time without notice. Raltron/RAMI Tech does not assume any liability arising out of an application or use of any product described herein and disclaims any warranties expressed or implied. The user of products in such applications shall assume all risks of such use and will agree to hold Raltron/RAMI Tech, harmless against all damages. Copyright © 2016, Raltron Electronics / RAMI Technology USA, LLC. All rights reserved. No part of this document may be reproduced in any form without the prior written permission of Raltron Electronics / RAMI Technology USA, LLC.