

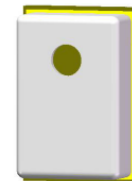

Description: The RMIC-94-3.6-2718-NX-NS1 is a high-performance, low power, bottom port MEMS microphone with single-ended analog output.

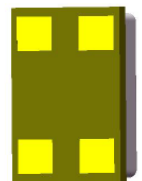

Top View



Bottom View

ACOUSTIC AND ELECTRICAL SPECIFICATIONS

Test Condition: VDD=2.0V, 23±2°C, 55±10%R.H., unless otherwise specified

Specification	Symbol	Test Conditions	Min.	Typ.	Max.	Unit
Directivity			Omni-directional			
Sensitivity Range	S	94dB SPL @1kHz	-43	-42	-41	dB
Output Impedance	Zout	94dB SPL @1kHz			250	Ω
Operating Voltage	VDD		1.6	2	3.6	V
Current Consumption	I	1.6V to 3.6V			200	μA
S/N Ratio	SNR	94dB SPL @1kHz, A-Weighted		52		dB(A)
Total Harmonic Distortion	THD	94dB SPL @1kHz			0.5	%
Sensitivity vs Voltage	ΔS	94dB SPL @1kHz, Vdd=3.6V to 1.6V			0.5	dB
Acoustic Overload Point	AOP	THD=10% @1kHz		130		dB SPL
Power Supply Rejection	PSR	0.1Vpp Square wave @217Hz, A-weighted		-90		dB

DIMENSIONS

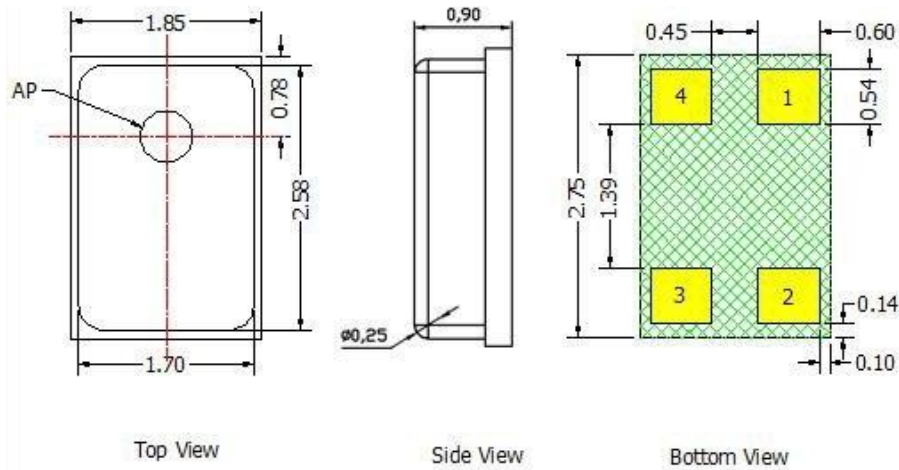

Item	Dimension	Tolerance(±)	Units
Length	2.75	0.1	mm
Width	1.85	0.1	mm
Height	0.9	0.1	mm
Acoustic Port	∅0.5	0.05	mm

Pin #	Definition	Type	Description
1	Output	Signal	Output Signal
2	GND	Ground	Ground
3	GND	Ground	Ground
4	V _{DD}	Power	Power Supply

Notes: Dimensions are in mm unless otherwise specified.

Tolerance is ±0.10mm unless otherwise specified

All Ground Pin must be connected to the ground in end application.

EXAMPLE LAND PATTERN

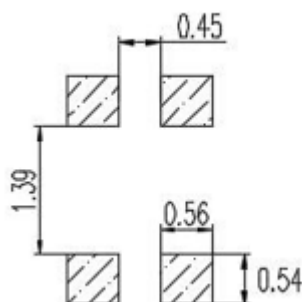

EXAMPLE SOLDER STENCIL PATTERN

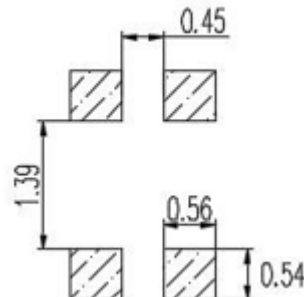

EXAMPLE PICK UP LOCATION

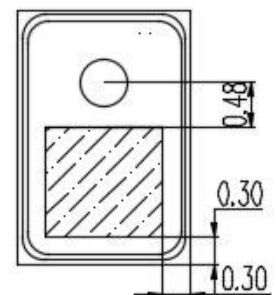

SCHEMATIC MEASURING DIAGRAM

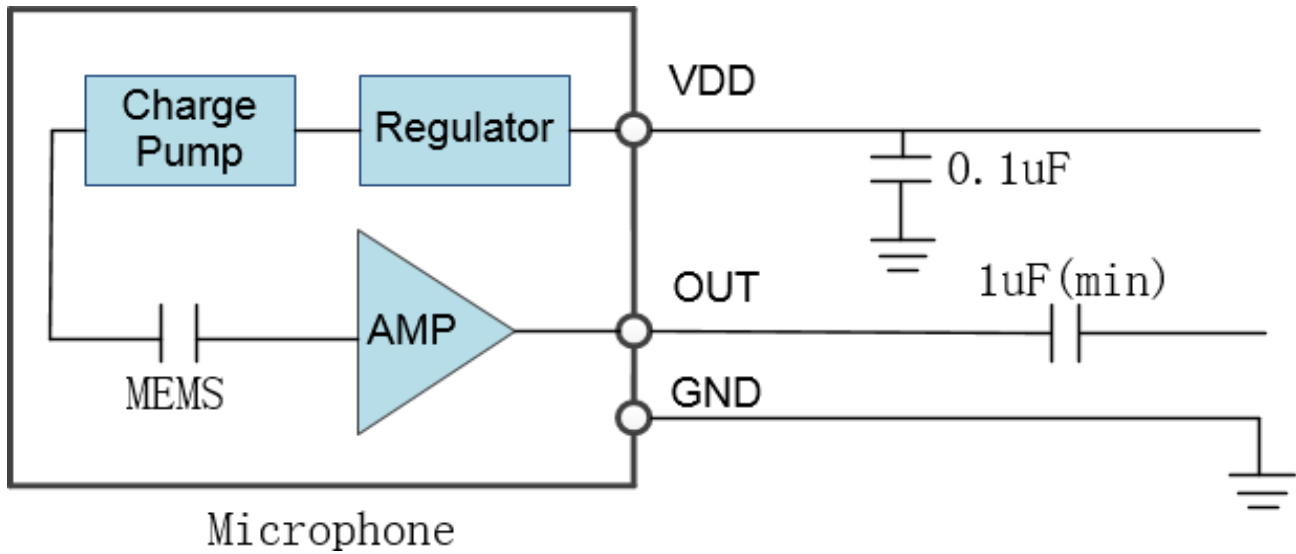

MEASUREMENT SYSTEM SETUP

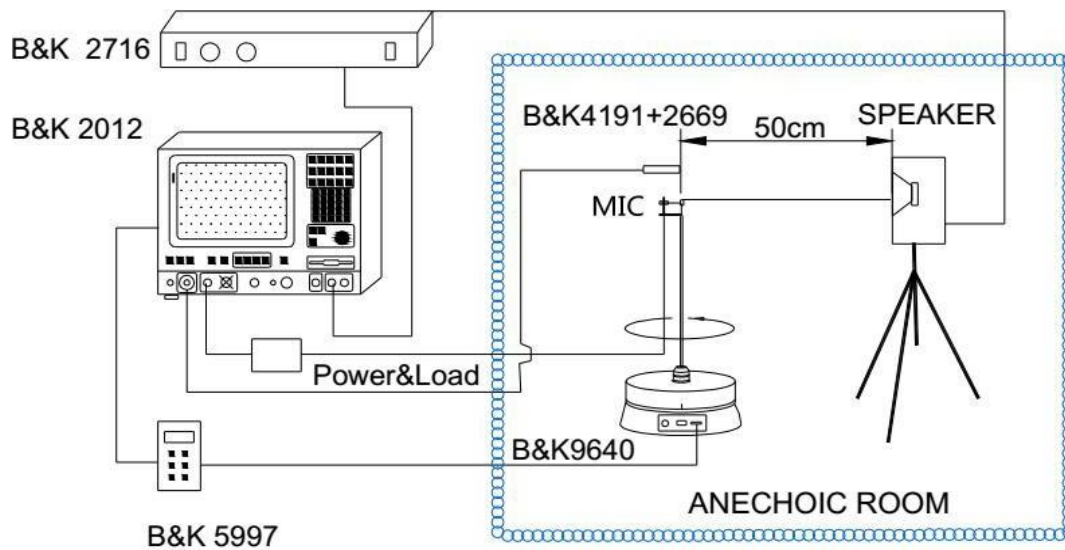

FREQUENCY CHARACTERISTICS

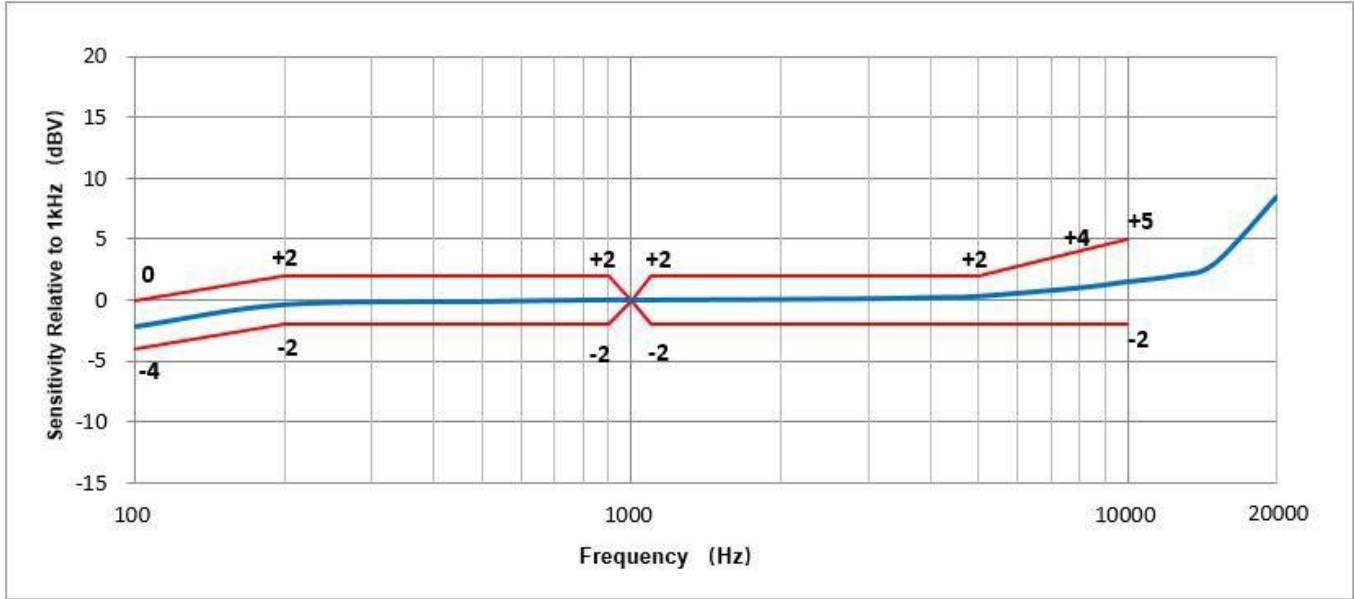

REFLOW PROFILE

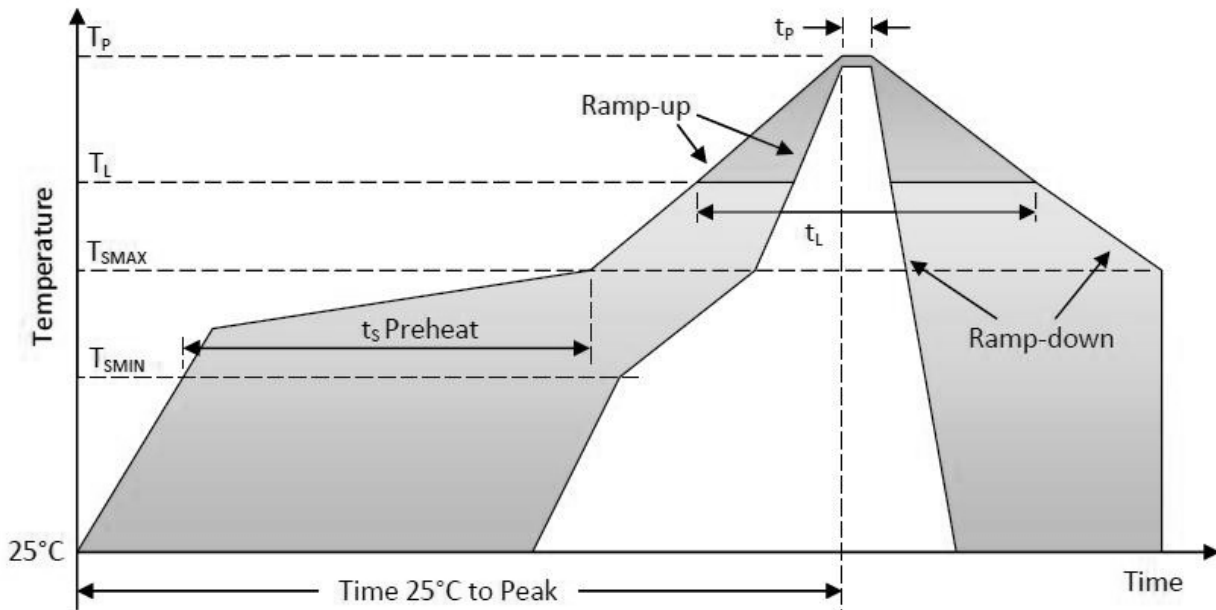

Parameter		Reference	Specification
Average Ramp-up Rate		T _L to T _P	3°C/sec max
Preheat	Minimum Temperature	T _S MIN	150°C
	Maximum Temperature	T _S MAX	200°C
	Time T _S MIN to T _S MAX	t _s	60 -180 sec
Ramp-up Rate		T _S MAX to T _L	1.25°C/sec
Time Maintained Above Liquidous		t _L	60-150 sec
Liquidous Temperature		T _L	217°C
Peak Temperature		T _P	260°C
Time Within +5°C of Actual Peak Temperature		t _P	20 -40 sec
Ramp-down Rate		T _P to T _S MAX	6°C/sec max
Time 25°C to Peak Temperature			8 min max

STORAGE CONDITION

Storage temperature range: -40 ~ +100°C, and humidity is less than 75%.

Operating temperature range: -40 ~ +100°C.

MSL (moisture sensitivity Level) is Class 1

RELIABILITY SPECIFICATIONS

The microphone should be placed in the room with 23 ± 2 °C, $55\pm 10\%$ R.H. for 2 hours at least before final measurement, unless otherwise specified. After conducting any of the following tests, the sensitivity change of DUT shall be less than ± 3 dB from its initial value unless otherwise noted, and shall keep its initial operation and appearance.

NO.	Item	Detail
1	Reflow	Samples for qualification testing require 3 Times 260 ± 5 °C reflow solder profiles. 2 hours of setting time is required between each reflow profile test.
2	Humidity Test	Precondition at $+25$ °C for 1 hour. Then expose to $+85$ °C with 85% relative humidity for 1000 hours.
3	Thermal Shock	Each cycle shall consist of 30 minutes at -40 °C, 30 minutes at $+125$ °C with 5 minutes transition time. Test duration is for 30 cycles, starting from cold to hot temperature.
4	ESD	According to MIL-STD-883G, Method 3015.7 for Human Body Model. Discharge Position: I/O pins Charge Voltage: ± 2000 V Discharge Network: 100pF & 1500 Ω
5	Vibration Test	Vibrate randomly along three perpendicular directions for 30 minutes in each direction, 4cycles from 20Hz~2000Hz with a peak acceleration 20g.
6	Mechanical Shock	Subject samples to half sine shock pulses ($3000g\pm 15\%$ for 0.3ms) in each direction, totally 18 shocks.
7	High temperature Storage	Microphone unit must maintain sensitivity after storage at $+105$ °C for 1000 hours.
8	Low temperature Storage	Microphone unit must maintain sensitivity after storage at -40 °C for 1000 hours.
9	Drop Test	The test was repeated in six directions for three times, Dropped from 1.5m height on to a steel surface, total 18 times and inspected for mechanical damage.

PACKAGING

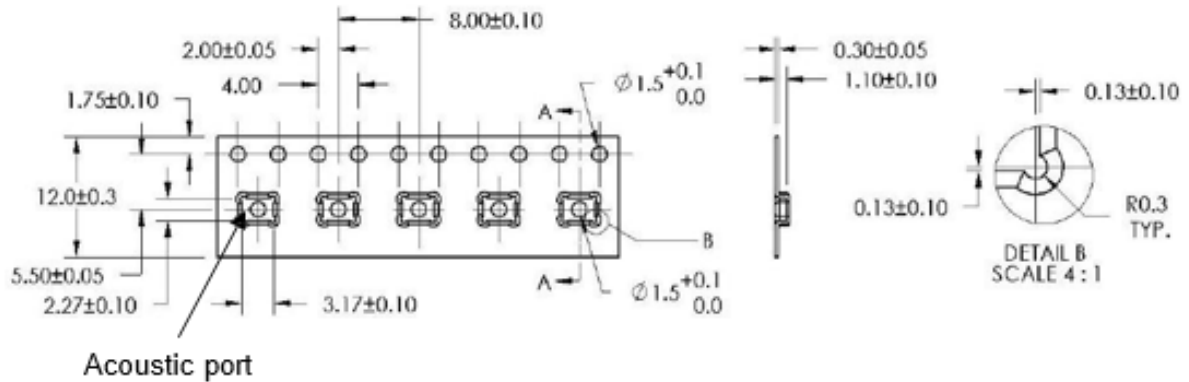

Acoustic port

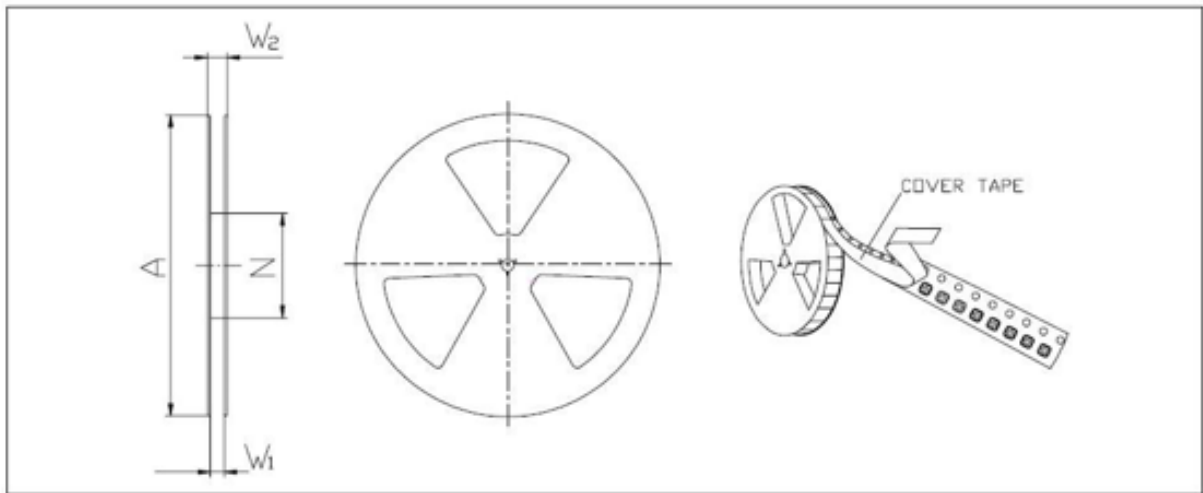

A	W1	W2	N	Quantity per Reel
Ø 330	12.4±1.5	18.4 MAX	Ø 100	5000

Unit: mm

APPROVAL

DRAWN BY	AR, January 13, 2025
APPROVED BY	CP, January 13, 2025
REVISION	A, Initial Release