

Electrical Specifications

1. ANTENNA

Parameters	Specification	Unit
Frequency Range	1575.42 ± 1.023	MHz
VSWR, max	1.5	-
Bandwidth, min	10	MHz
Impedance	50	Ω
Gain (based on 70x70mm ground plane)	1.5	dBic
Polarization	RHCP	-
Operating Temperature Range	-25 ~ +72	°C
Storage Temperature Range	-45 ~ +85	°C

2. LNA

Parameters	Specification	Unit
Frequency Range	1575.42 ± 1.023	MHz
DC Voltage	3.0 ± 0.3	V
Gain	27	dB
Output VSWR, max	2.0	-
Noise Figure, max	1.5	dB
DC Current, typ	13 ± 2	mA

Cable and Connector

Parameters	Specification	Unit
RF Cable	Length	120 ± 2
	Diameter	1.13 ± 0.1
RF Connector	IPEX - 1	-

Mechanical Characteristics

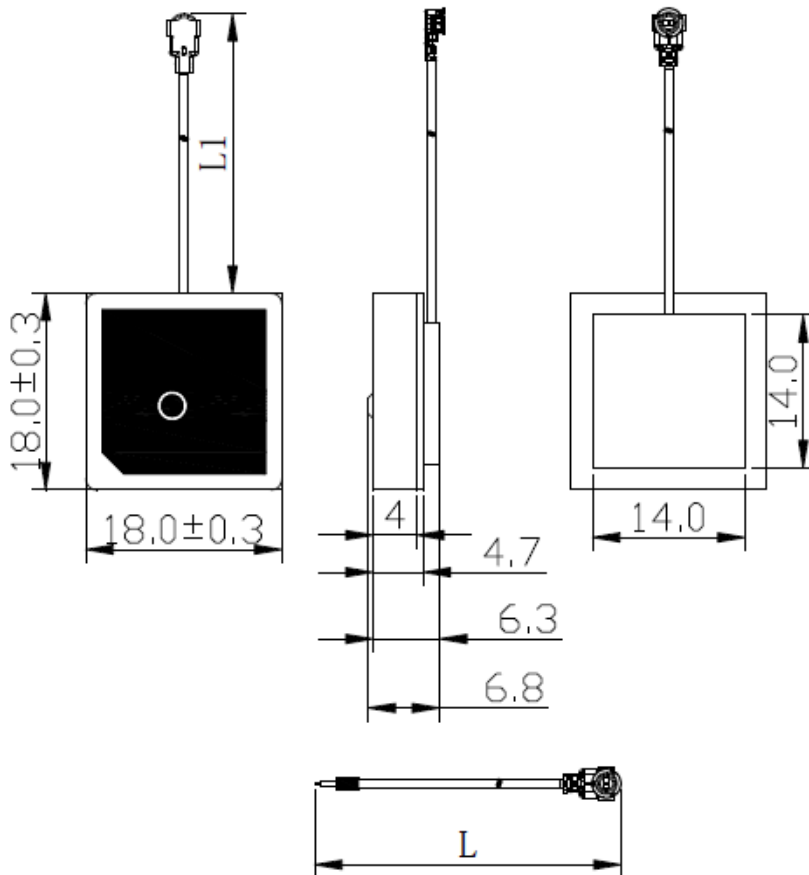

L = 120 ± 2 mm
L1 = 110 ± 2 mm

Frequency Characteristics

ANTENNA TEST CURVE

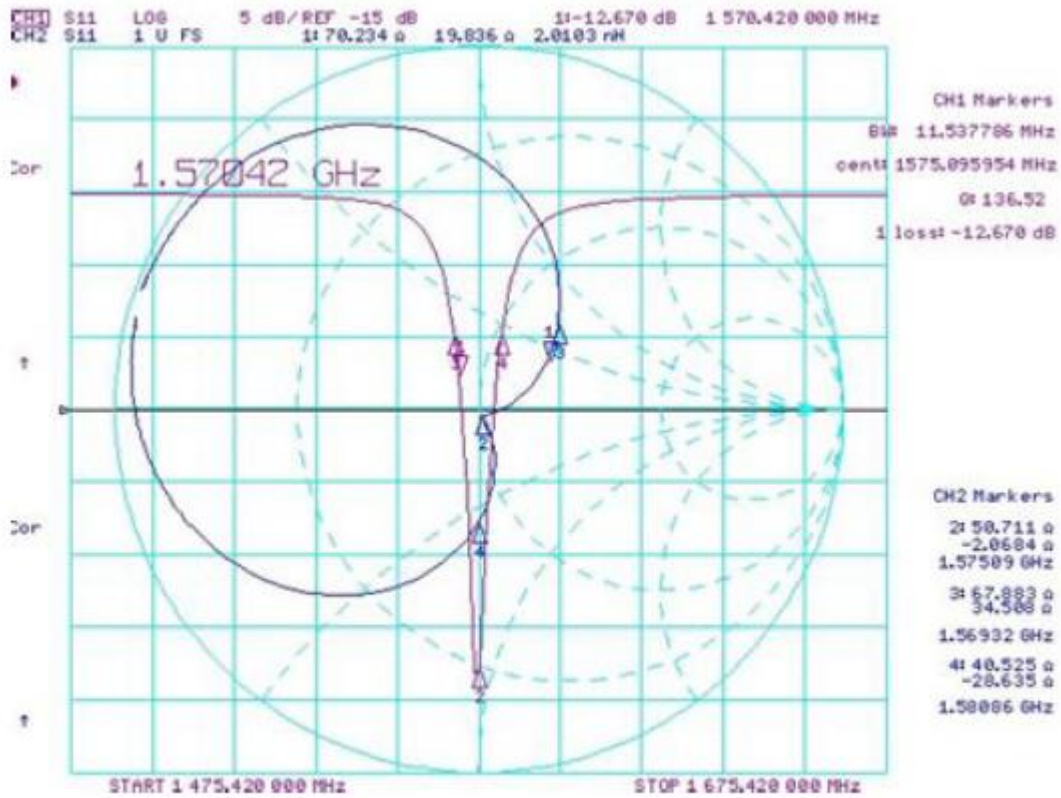

APPROVAL

DRAWN BY	CP, February 05, 2016
APPROVED BY	CP, February 05, 2016
REVISION	A, Initial Release