

### CO2016A SERIES: 2.0 x 1.6 mm CLOCK OSCILLATOR



#### ■ FEATURES

- ULTRA SMALL PACKAGE
- LOW SUPPLY VOLTAGE 1.6 AVAILABLE
- STANDBY FUNCTION
- RELIABILITY TESTING PER AEC-Q200

#### ■ ELECTRICAL SPECIFICATION

PARAMETER		VALUE	
Frequency Range		32.768 kHz	
Frequency Stability <sup>1</sup> *		±20**ppm, ±50 ppm, ±100 ppm	
Supply Voltage		1.6, 2.5, 3.3 V	
		1.6 ~ 3.3 V	
Supply Current		200µA, max	
Output CMOS		Symmetry @50% Vdd	
		40% to 60% Standard 45% to 55% Tight	
Rise / Fall Time		60 ns max at 10% to 90% Vdd	
Logic "0" Level		Vcc x 0.1 V max	
Logic "1" Level		Vcc x 0.9 V min	
Load		15 pF max	
Enable / Disable Function		Pin 1: Open or High, Pin 3: Oscillation (Enabled), min	Vcc x 0.7 V
		Pin 1: Low, Pin 3: High Impedance (Disabled), max	Vcc x 0.3 V
Start-up Time		10 ms max	
Standby Current		10µA max	
Operating Temperature Range		-40°C ~ +85°C	
		-40°C ~ +105°C	
		-40°C ~ +125°C	
Storage Temperature Range		-55°C ~ +125°C	

\* Inclusive of 25°C tolerance, operating temperature range, voltage and load changes, aging, reflow

\*\* Not available for all Temperature Ranges. Contact Factories

### CO2016A SERIES: 2.0 x 1.6 mm CLOCK OSCILLATOR

#### MECHANICAL SPECIFICATION (4 pin ceramic package)

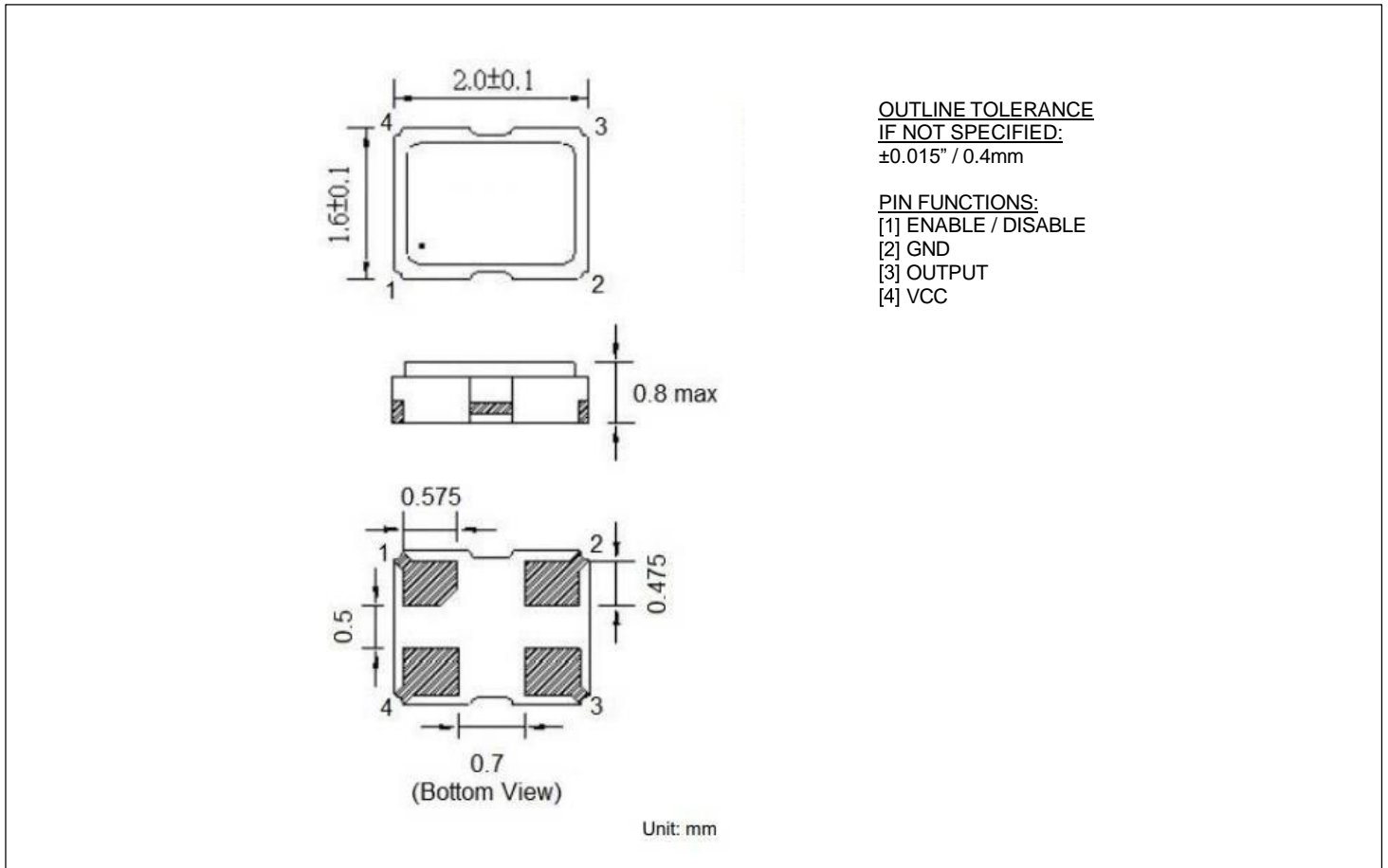

#### PART NUMBERING SYSTEM

TYPE	SERIES	-	FREQUENCY (MHz)	-	SUPPLY VOLTAGE (Vcc)	-	STABILITY (ppm)	-	TEMPERATURE RANGE	-	SYMMETRY (Duty Cycle)	-	TAPE & REEL
Clock Oscillator CO	2016A	-	0.032768	-	1.8: Vcc=1.8 2.5: Vcc=2.5 3.3: Vcc=3.3	-	20: ±20 50: ±50 100: ±100	-	X: -40°C ~ +85°C X1: -40°C ~ +125°C X6: -40°C ~ +105°C	-	blank: 40 ~ 60% T: 45 ~ 55%	-	TR

#### EXAMPLE: CO2016A-0.32768-3.3-100-X1-T-TR

Surface Mount Crystal Oscillators CO2016A, 2.0 x 1.6 mm, 32.768 kHz, 3.3 VDC Supply Voltage, ±100 ppm Overall Stability, from -40°C to +125°C, Symmetry 45% to 55%, Tape and reel packaging.

### CO2016A SERIES: 2.0 x 1.6 mm CLOCK OSCILLATOR

#### REFLOW PROFILE

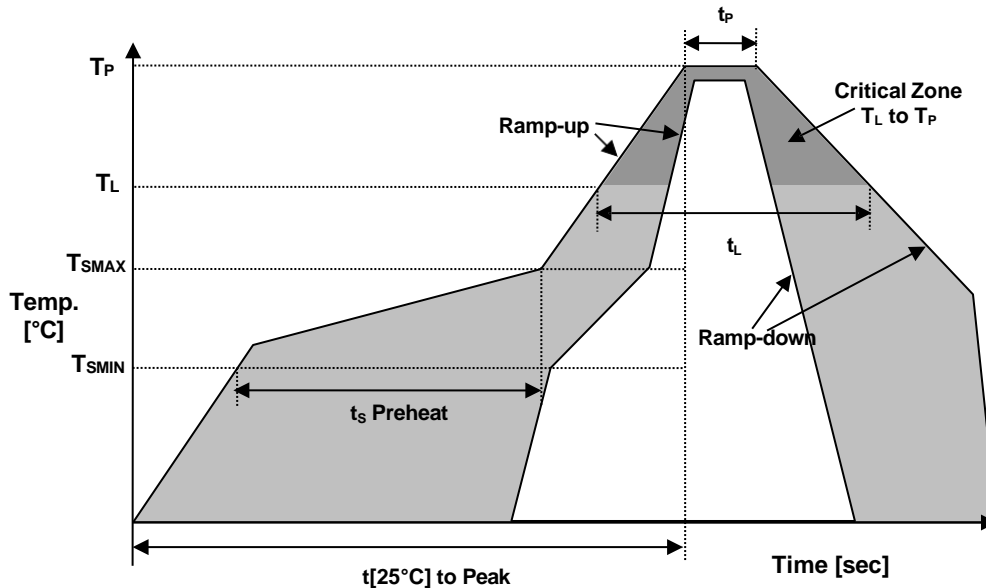

Reflow profile		
Temperature Min Preheat	T <sub>SMIN</sub>	150°C
Temperature Max Preheat	T <sub>SMAX</sub>	200°C
Time (T <sub>SMIN</sub> to T <sub>SMAX</sub> )	t <sub>s</sub>	60-180 sec.
Temperature	T <sub>L</sub>	217°C
Peak Temperature	T <sub>P</sub>	260°C
Ramp-up rate	R <sub>UP</sub>	3°C/sec max.
Ramp-down rate	R <sub>DOWN</sub>	6°C/sec max.
Time within 5°C of Peak Temperature	t <sub>p</sub>	10 sec.
Time t[25°C] to Peak Temperature	t[25°C] to Peak	480 sec.
Time	t <sub>L</sub>	60-150 sec.

#### ENVIRONMENTAL

PARAMETER	VALUE
MOISTURE SENSITIVITY LEVEL	1
REACH SVHC	Compliant
RoHS	Compliant
TERMINATION FINISH	Au



Raltron Electronics/RAMI Technology USA, LLC, including its affiliates, employees, agents and other persons acting on its behalf (collectively Raltron/RAMI Tech), disclaim any and all liability for any errors or inaccuracies contained in this data sheet. While Raltron/RAMI Tech has made every reasonable effort to ensure the accuracy of all product information, specifications and data contained herein, Raltron/RAMI Tech does not guarantee that the information is accurate, reliable or current. The product information is provided for reference purposes only and is subject to change, correction or revision, at any time without notice. Raltron/RAMI Tech does not assume any liability arising out of an application or use of any product described herein and disclaims any warranties expressed or implied. The user of products in such applications shall assume all risks of such use and will agree to hold Raltron/RAMI Tech, harmless against all damages.

---

## CO2016A SERIES: 2.0 x 1.6 mm CLOCK OSCILLATOR

The process of manufacturing **CO2016A** series of Automotive Grade Clock Oscillator is performed by using **Advanced Product Quality Planning (APQP)**. This technique defines and establishes the following actions:

- Product design activities communicating special characteristics to the process design activity, prior to design release, linking the DFMEA to PFMEA.
- Plan, acquire and install appropriate process equipment and tooling based on design tolerances provided by the customer. – CPPD (Collaborative Product Process Design)
- Assembly personnel communicating suggestions on better ways to assemble a product prior to the completion of the design of the product. – DFA/M (Design for Assembly and Manufacturing)
- Manufacturing or Process Engineering establishing adequate Quality Controls for features of a product or parameters of a process, which still risk potential failure. – Control Plan Methodology
- Performing Stability and Capability studies on special characteristics to understand the variation present and predict future performance. – SPC (Statistical Process Control and Process Capability)

Request for **Production Part Approval Process (PPAP)** documentation must be requested at time of order placement. Requests for part approval will be supported in official PPAP format and with documented results as requested at time of order placement. Actual measurements are taken of the parts produced and are used to complete the various test sheets of PPAP.

### • NOTICE

If you intend to use our product referenced above in an automotive application that may result in loss of life or assets, please do not fail to advise us of your intention beforehand. The use of the listed part in those applications is not covered by warranty, and we will not be held accountable for any liability claims. We reserve the right to not supply parts in those circumstances.